

HISTORY OF FUEL INJECTION

By FRANK DeLUCA, Chief Fuel Injection Engineer, of American Bosch Arma Corporation

History of Fuel Injection

When Rudolph Diesel contracted with Augsburg and Krupp of Germany in 1893 to develop a more efficient internal combustion engine, one of his objectives was to use as fuel the mountainous piles of powdered coal which had been accumulating throughout the countryside. The first experimental coal dust burning engine was built that year using air to blast the fuel into the combustion chamber. His method is shown schematically in Fig. 1, which was reproduced from U. S. patent No. 542846 granted in 1895. The powdered coal was contained in hopper B provided with rotary valve D, and the compressed air was stored in tank A. When the injection valve E was lifted, the high pressure air flowed into the combustion chamber C through orifice F carrying with it the coal discharged through the rotating valve F. In attempting to start the engine it exploded, and all subsequent efforts to operate the engine on coal dust failed, so that oil was finally adopted as the fuel.

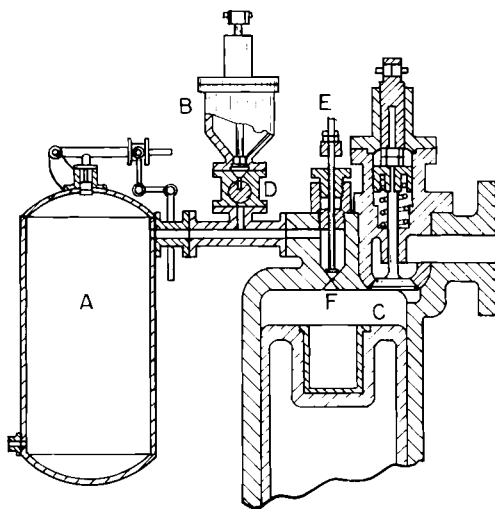

Fig. 1. Coal dust injection system of Rudolph Diesel.
(After U.S. patent No. 54286 of 1895.)

In the first experiments with oil, it was mechanically injected into the engine. The results were unsatisfactory, probably because of the crude injection equipment with large dead fuel volume, so that Dr. Diesel resorted to using the compressed air equipment available from his coal dust experiments. His first tests with air injection proved so successful that this became the accepted method of injection for many years. Thus, early in the development of this new engine the importance of the fuel injection process on engine combustion was emphasized, and subsequent progress in diesel engine development has been largely dependent upon improvements in fuel injection.

AIR INJECTION

The operating principle of most air injection systems has been similar to the one first used by Rudolph Diesel. Fuel oil was metered and delivered by a pump to the atomizer, which was in communication with a high pressure air storage tank supplied by an air compressor, and injection occurred when the injector valve was opened by a cam actuated mechanism. High pressure air then flowed into the engine cylinder carrying along with it the metered fuel as a finely atomized spray.

The construction of Diesel's fuel atomizer has not been fully established, but most of the early designs of atomizers had a series of 1/8 inch diameter holes through which the air and fuel passed before entering the combustion chamber. The perforated disc atomizer, shown in Fig. 2 (see following page), came into use about the year 1900. It consisted of a mechanically operated valve surrounded by a stack of drilled discs, or pulverizer rings, on

which the oil was deposited and then blown by compressed air into the engine cylinder during injection.

In 1908 Knut Hesselman of Sweden disclosed an aspirating valve atomizer which became popular for small air injection engines. As shown in Fig.3, the metered oil was deposited

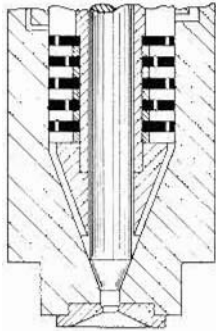

Fig. 2. Perforated disc atomizer.

scheme failed because the exhaust temperatures were not high enough to develop the required steam pressure for injection with the exhaust heated boiler.

SOLID INJECTION

One of the first satisfactory airless injection system was applied to an engine in 1910 by James McKechnie of Vickers, Ltd. of England. As shown in Fig.4 (see following page), oil was delivered by a metering pump to a spring loaded plunger, which was raised by a cam. Tripping of the cam allowed the fuel to be injected into the engine cylinder as the spring returned the plunger to its bottom position.

Common Rail

In 1913 Vickers, Ltd. developed the common rail system which became very popular. A multi-plunger pump delivered fuel to an accumulator and header of large capacity with the fuel pressure maintained at about 5000 psi by a relief valve, and the fuel was sprayed into the engine cylinders through mechanically operated injection nozzles. Fuel metering was controlled by varying the period of opening of the injection valves. The first American engine with common rail injection system was built by the Atlas Imperial Diesel Company of Oakland, California in 1919.

Jerk Pumps

The originator of plunger pumps for forcing a metered quantity of fuel at high pressure into the engine cylinders is difficult to trace. Richard Hornsby & Sons of England used jerk pumps in 1891 and Ruston, Proctor & Co., also of England, used a similar type pump in 1909. In 1914 De La Vergne Company of Philadelphia used a jerk pump that delivered fuel at a very high rate (full load delivery in about 12 crankshaft degrees) to two single hole, swirl type nozzles located opposite each other in the combustion chamber.

in an annular space above the valve seat, and when the valve was lifted an aspirating effect was produced on the oil to discharge it along with the air flowing past into the combustion chamber. Numerous other variations of atomizer designs were tried, but with little or no commercial success.

The early Krupp engines used single-stage air compressors, and it was not until after the turn of the century that three-stage compressors were introduced on engines built by the Diesel Motor Company of America. Steam for fuel injection was attempted by Thornycroft of England in 1903, but the

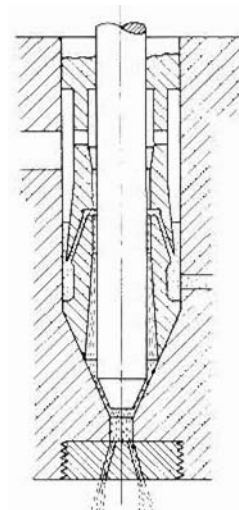

Fig. 3. Aspirating valve atomizer of K. Hesselman. (After U.S. patent No. 910534 of 1909.)

INJECTION PUMPS

The one feature common to all injection pumps from the earliest to the present has been the use of plungers to create the required injection pressure. Early pumps relied upon packed glands to minimize the leakage of high pressure fuel past the plunger. The earliest

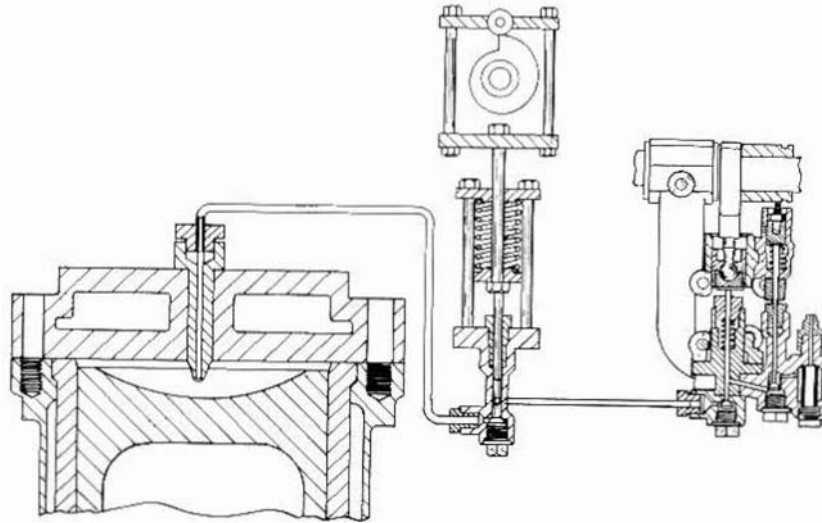

Fig. 4. The McKechnie solid injection system

reference to close fitting of the plunger and barrel for elimination of the packing gland appears in a patent filed in 1912 by Otto F. Persson of the United States. In 1919 Philip L. Scott, also an American, described a method of fitting a plunger to a barrel with an estimated clearance of 0.0001 inch.

Metering Methods

The earliest known method for varying the fuel quantity delivered by a pump was to vary the plunger stroke. An American, John F. Holland, obtained patent No. 337,000 in 1886 on an arrangement for sliding a camshaft with tapered cams to vary the pump stroke.

Another early method of metering control was by means of a spill valve. In 1900 U.S. patent No. 654,140 was granted to Rudolph Diesel for a wedge controlled spill valve pump as shown in Fig. 5. The duration of the plunger stroke during which the by-pass valve D was closed was lengthened or reduced by moving the wedge K in or out, thus increasing or decreasing the fuel quantity delivered by the pump.

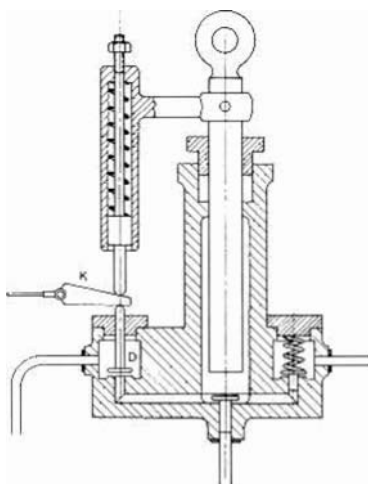

Fig. 5. R. Diesel's metering pump with spill valve controlled by a wedge. (After U.S. patent No. 654140 of 1900)

Fuel metering control by means of a helix on plunger was introduced by Carl Pieper of Germany in 1892. According to his German patent No. 66,057 and as shown in Fig. 6 (see following page), a suction port was controlled by a top beveled plunger, and by rotating the plunger a variation of the port closure time was effected to change the fuel quantity delivered by the pump.

English patent No. 9403 was granted to William H. Scott in 1895 for a double port helix control for varying both the beginning and ending of injection.

Control of the fuel quantity by suction valve timing was quite popular for early injection pumps. It was introduced by Imanuel Lanster of Germany in 1902. According to his U.S. patent No. 729,613 issued in 1903, a governor controlled linkage connected to the pumping plunger would hold the spring loaded suction valve open for a longer or shorter time to decrease or increase the quantity of fuel injected.

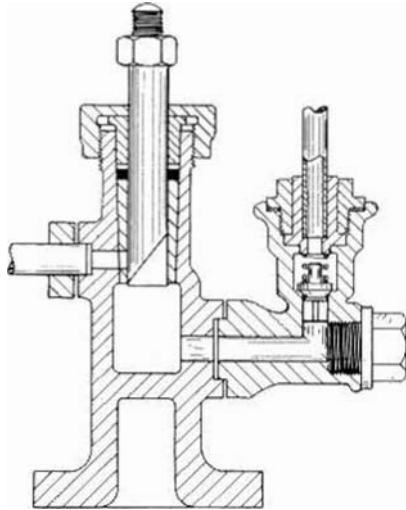

Fig. 6. Pump with plunger helix control. (After Carl Pieper's German patent No. 66057 of 1892.)

Distributor Pumps

In 1914 British patent No. 15,962 was granted to Francois Feyens of Belgium for an injection system using a rotary distributor to deliver metered fuel to the several cylinders of a multi-cylinder engine. As shown in Fig. 7, fuel at a regulated high pressure was delivered to chamber A from which it flowed into the tapered slot B of the cylindrical distributor C. As the distributor rotated in synchronism with the engine crankshaft, fuel was distributed to the various outlets D by means of slot B uncovering the ducts E. The fuel quantity was increased or decreased by lowering or raising the distributor to vary the effective width of slot B. The British motor ship "Selandia," launched in 1913, used a distributor type injection system on its first voyage to the Far East.

Delivery Valves

One of the problems encountered with early jerk pump injection system was the dripping or after injection of fuel following the main discharge. Since this resulted in smoke, increased fuel consumption, and nozzle carbonization, numerous attempts were made to vent the discharge tubings between injections.

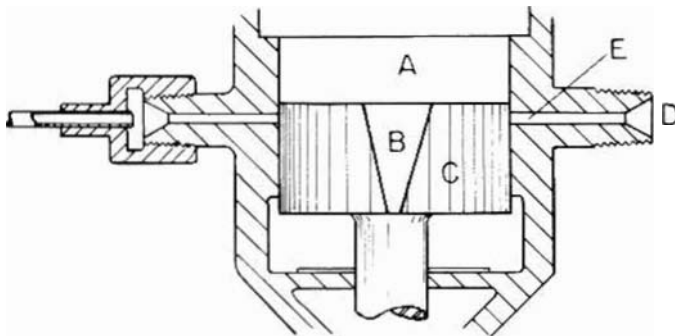

Fig. 7. Rotary distributor metering device. (After Francois Feyens' British patent No. 159962 of 1914.)

In 1910 an American, Herbert Kempton, proposed a delivery valve having a hole in it through which the high pressure fuel was relieved when the plunger returned on its downward stroke.

The first suggestion to use a collar on the delivery valve to retract part of the fuel from the discharge tubing was made by Karl Steinbecker in Germany in 1913, and he was granted U. S. patent No. 1,235,611 On it in 1917. In 1920 Van Amstell of Holland described a non-return valve having a cylindrical piston directly below the valve seat to withdraw a portion of the Liquid before the valve seated.

In 1924 Axel Danielson of the Atlas Diesel Company of Sweden introduced a retraction type delivery valve for which he was granted U.S. patent No. 1,589,515 in 1926. It embodied the one feature his predecessors had been striving for: automatic pressure relief of the discharge tubing immediately after the end pump discharge under all conditions. As shown in Fig. 8 (see following page), the valve had a close fitting piston beneath its seat, so that the lower edge of the piston effected a seal as it entered the bore on the reseating of the valve. The effective retraction was the volume displaced from the lower edge of the piston to the tapered seat of the valve.

The duplex delivery valve was first proposed by Eugene Tartrais of France in 1921, and he was granted U. S. patent No. 1,492,111 on it in 1924. It consisted of a small valve inside of the main valve and opening in the opposite direction. Thus, when fuel delivery from the pump ceased and the main valve seated, the high pressure in the discharge tubing was relieved through the small valve until its closing pressure was reached.

The variable retraction delivery valve was developed in 1934 by Hans Heinrich and Max Hurst of Robert Bosch in Germany, and U. S. patent No. 2,090,351 was granted on it in 1937. Its variable retraction feature consisted of tapered grooves, increasing in width from top to bottom, on the cylindrical guide of the valve.

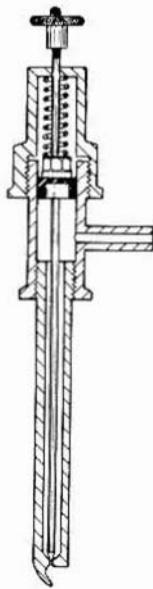

Fig. 9. Inwardly opening valve nozzle

Inwardly Opening Valve

James Hargreaves of England was granted U.S. patent No. 431,581 in 1890 on the first nozzle of this type. As shown in Fig. 9, the valve was lifted off its seat by fuel pressure acting on the piston in opposition to the spring. In common with other early designs, this was a low pressure nozzle. A lip projection was added below the orifice so that the issuing fuel impinged on it to effect better atomization of the fuel.

Differential Valve

The inwardly opening, differential valve type nozzle, which is the most popular nozzle today, was first used by Thornycroft of England in 1908. Fig. 1.0 (see following page), shows the construction of this nozzle. In 1910 Frederick H. Livens of England was granted English patent No. 20,582 on a similar nozzle with tangential fuel channels for the fuel entering at the seat to produce a diffused spray.

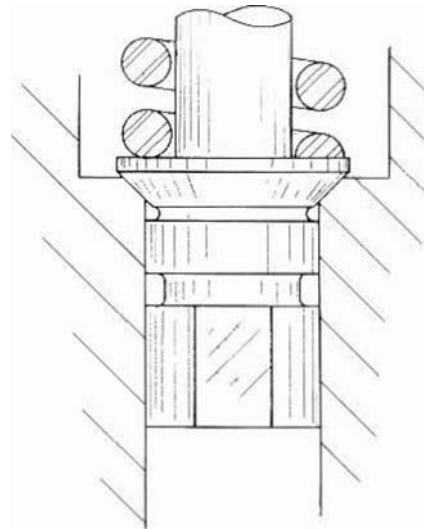

Fig. 8. Delivery valve with retraction piston. (After Axel Danielson's U.S. patent No. 1,589,515 of 1926.)

FUEL SPRAY NOZZLES

Fuel injection was first used in otto cycle engines before the invention of the Diesel Engine. The objective was to obtain better atomization of the pressurized fuel through spray nozzles than was possible with the crude carburetors of that time.

Poppet

In 1886 an American, John P. Holland, was granted U. S. patent No. 537,000 on an engine accessory, including a poppet nozzle, which he claimed would burn kerosene and heavy crude petroleum as well as the lighter naphthas commonly used for fuel in a vaporizer, where it was mixed with the incoming air before entering the combustion chamber. In 1900 U.S. patent No. 650,583 was granted to A. H. Goldingham for a poppet nozzle with an orifice plate below it.

Pintle Valve

In 1910, Peter Bowman of Denmark applied for a patent in England on what may be the earliest form of an inwardly opening, pintle nozzle. As shown in Fig. 11, the pintle, or valve extension, protruded through the sprayhole to produce an annular orifice, and the seat for the flat bottom valve was close to the orifice so that the nozzle had differential action. Hans Heinrich of Robert Basch, Germany was granted U.S. patent No. 2,017,028 in 1935 on the popular throttling pintle nozzle.

Accumulator Type

In 1926 an American, Guy Bell, was granted patent No. 1,585,277 on an accumulator nozzle which injected at the end of the pump stroke, rather than during it. As shown in Fig. 12 (see following page), fuel from the pump was delivered to a space above the valve A and through passages and check valve B to the accumulator C in communication with the chamber D around the valve.

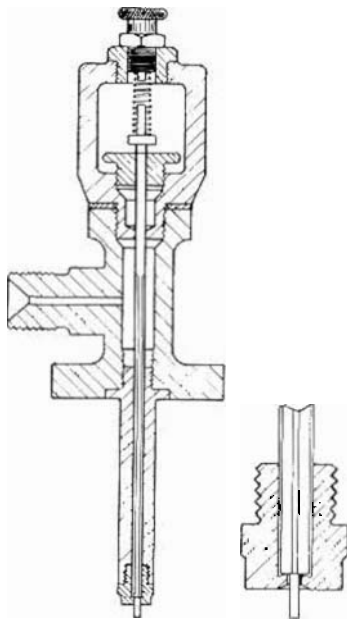

Fig. 11. Inwardly opening pintle valve nozzle. (after Peter Bowman's British patent No. 146 of 1910.)

a high pressure pump and regulated by a relief valve. Harry E. Kennedy was granted U.S. patent No. 1,092,956 on a novel construction of an electro-magnetic nozzle valve in 1933, and the Atlas-Imperial Diesel Engine Company of California about that time announced a commercial injection system with this type of nozzle.

UNIT INJECTORS

From the earliest days of the diesel engine, troubles were encountered with the fuel

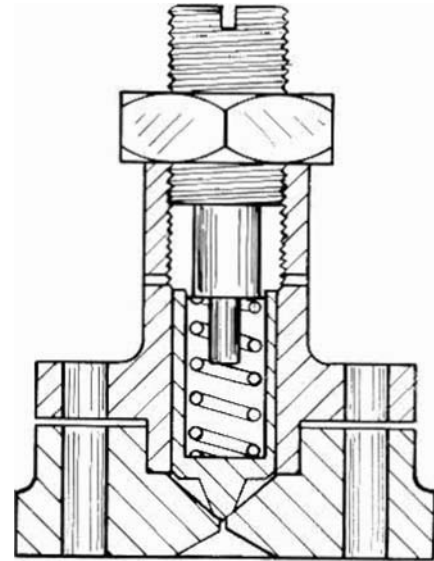

Fig. 10 Inwardly opening differential nozzle of Thornycroft

During fuel delivery from the pump the nozzle valve remained seated, because the pressure of the incoming fuel acted on top of the valve. When the pump spilled at the end of its effective stroke the high pressure fuel above the valve dropped to a low pressure, and the pressure of the fuel stored in the accumulator and around the valve then acted on the differential area of the valve to lift it against the spring. The stored fuel then discharged through the nozzle orifice until its pressure dropped to the nozzle valve closing pressure. U.S. patent No. 1,701,089 was granted in 1929 to Edward Von Salis of Switzerland for a nozzle with a spring operated accumulator plunger, and other modifications were made later by Robert Broege in 1931 and Gustav Eichelberg in 1939.

Electro-magnetically Operated

The idea of lifting nozzle valves by solenoids was first suggested by an American, Thomas T. Gaff, who obtained U.S. patent No. 1,059,604 on it in 1913. He proposed such a nozzle for each engine cylinder with fuel supplied from a constant pressure accumulator charged by

discharge tubings connecting the injection pump and nozzles. One solution was to eliminate the tubing by combining the pump and nozzle. The earliest form of this arrangement is shown in Fig. 13 reproduced from German patent No. 175, 932 issued to Carl Weidman In 1905 for an air injection system. In operation the fuel quantity delivered by plunger A and controlled by the opening period of suction valve B passed through check valve C into the atomizer annulus D. There it mixed with the injection air before ejection through the nozzle orifice.

In 1911 British patent No.1517 was issued to Frederick Lamplough for a unit injector resembling those in use today. As shown in Fig. 14 (see following page), it was of simple design. Inlet fuel entered through the top and passed through spring loaded ball valve A and ports B into the space above the plunger C on its suction stroke. When the bell crank forced the plunger inward, the differential valve D was lifted by fuel pressure and fuel was discharged through the nozzle. Fuel quantity was controlled by varying the stroke by means of the sliding, tapered cam.

Commercial acceptance of unit injectors in the United States commenced in 1931 on Winton engines with a design by C.D. Salisbury. In 1934 Arthur Fielden was granted U.S. patent NO.1,981,913 on the unit injector design adopted for the General Motors two-cycle diesel engine.

COMMERCIAL INJECTION EQUIPMENT

From the first successful diesel engine to 1926, each engine manufacturer designed and built his own injection equipment. Since these engine manufacturers were not accustomed to make small, precision parts requiring close tolerances, the cruder air injection and common

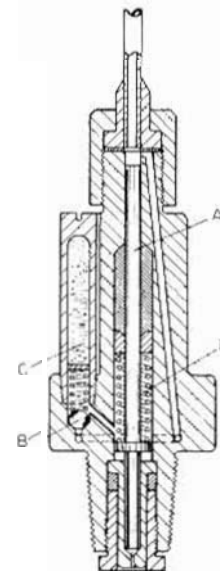

Fig. 12. Accumulator nozzle (After Guy A. Bell's U.S. patent No.1,585,277 of 1926.)

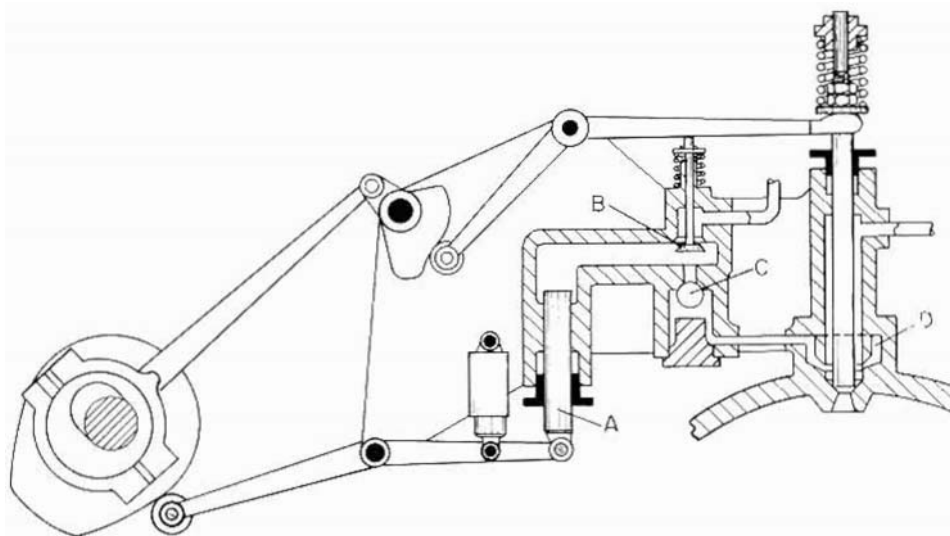

Fig. 13. Early unit injector. (After Carl Weidman's German patent No.175,932 of 1905.)

rail fuel injection systems were used exclusively on the rather large engines of that period. Small engines, especially of the automotive type, were not particularly successful, primarily because of the lack of suitable fuel injection equipment.

In December, 1922 the Robert Bosch Company of Stuttgart, Germany decided to manufacture fuel injection equipment, and after years of development its popular jerk pump with helix control, for which U. S. patent No. 1,831,649 was granted to Ottmar Bauer in 1931, was introduced in 1927 in both single and multiple plunger types. About the same time precision nozzle assemblies of the pintle and hole type were introduced, and subsequently other items such as supply pumps, governors, and filters were marketed. With the availability of this injection equipment the high speed diesel engine came into existence. In a relatively short time other companies started manufacturing standardized types of fuel injection equipment for all types of engines and progress in diesel engine development swung into high gear.

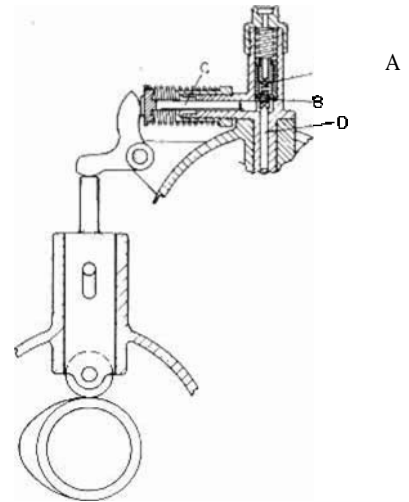

Fig. 4 Unit injector with differential nozzle valve.
(After Frederick Lamplough's British patent No. 1,517 of 1911.)